

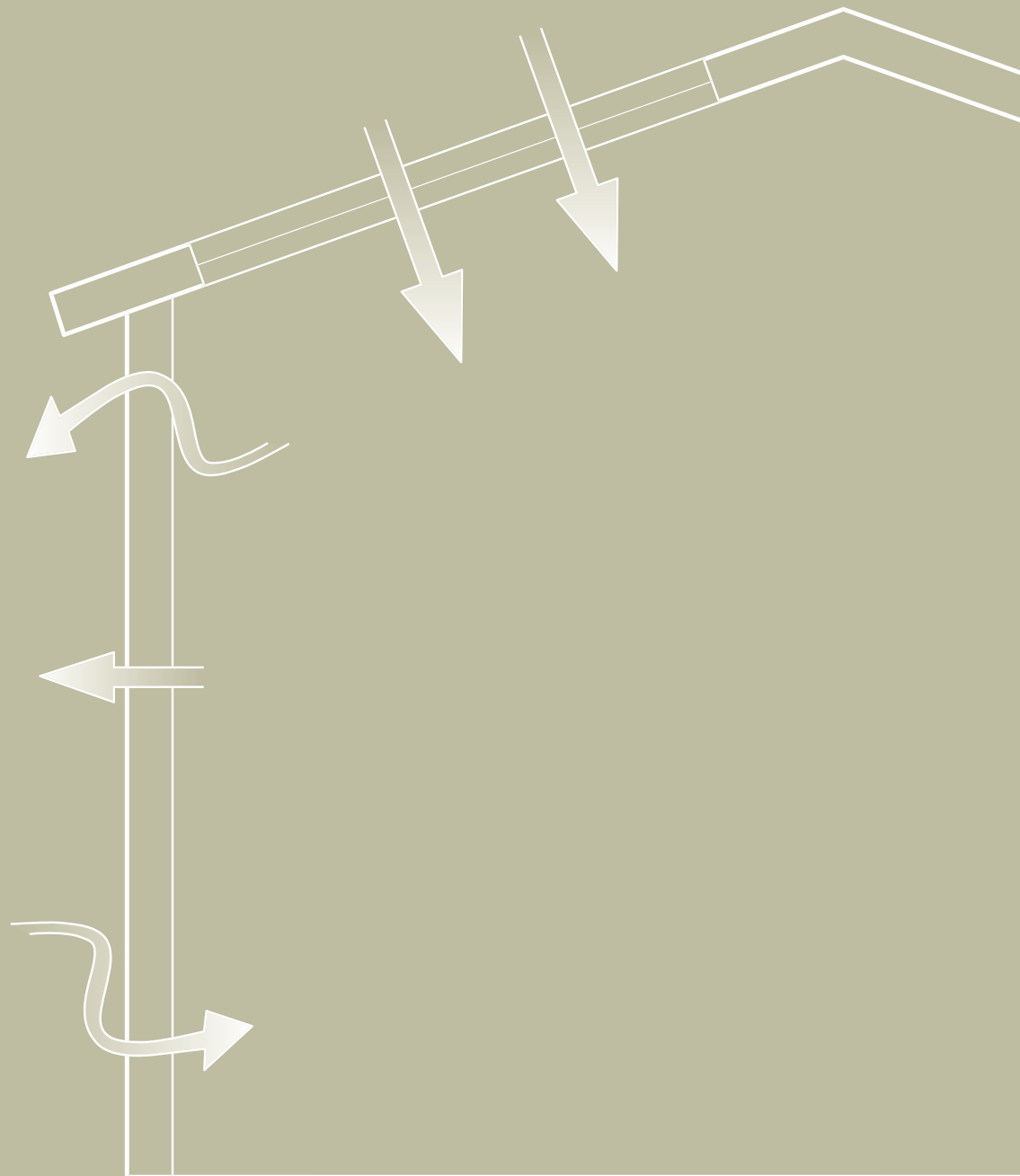

Corus Colors

Colorcoat® Technical Paper

Creating an air-tight building envelope



Corus and Part L

Over 40 years, Corus has developed close strategic relationships with a number of market-leading roof and wall cladding system manufacturers.

Specifying Colorcoat® products through one of these strategic partners ensures access to the very best technical guidance and the highest levels of quality and service. Together we can provide a quality building envelope solution that delivers peace of mind.

Working together to deliver Part L (2006) compliance

Corus has worked closely with CA Group, Corus Panels and Profiles and Euroclad to prepare for the changes to Part L (2006) Building Regulations. This has involved developing a consistent approach, testing all systems for air-tightness and sharing best practice on thermal modelling of details.

Corus, along with each of these strategic partners, prepared fully for the change to Part L regulations in April 2006. Moreover, we have developed the data and details which will help architects demonstrate compliance with the new regulations.

Contents

Overview	3
Significance of air-tightness on building energy performance	4
Air-tightness testing facilities	8
Achieving air-tightness using built-up systems	10
Achieving air-tightness using factory insulated composite panel systems	14
Applying the results in building design and construction	18
Air-tightness in context	20
Conclusion	21
The Colorcoat® brand	22

Overview

Environmental concerns and the rising cost of fuel mean that there is an increased focus on minimising energy use during the life of a building. The thermal performance of the building envelope plays a key role in this and tests show that achieving an air-tight envelope construction can more reliably create an energy efficient building than simply increasing levels of insulation. Metal-based cladding systems are inherently airtight and therefore ideally suited to creating an airtight building envelope.

This Colorcoat® Technical Paper shows designers and constructors how a good level of air-tightness can be achieved

using Corus Colorcoat® pre-finished steel products. It provides a short overview of the Part L Building Regulation requirements for air-tightness and practical guidance on the common methods of jointing both built-up and factory insulated composite panel systems. The Corus Colorcoat® Centre for the Building Envelope based at Oxford Brookes University has developed one of the world's most advanced testing facilities for assessing the air-tightness of building details. These facilities were used to test the air leakage rates using different joint configurations and the results are included in this paper.

Significance of air-tightness on building energy performance

Changes to Part L (implemented from April 2006) and rising energy prices have put a renewed emphasis on improving the energy performance of buildings. Studies have shown that the simple approach of increasing insulation thickness is unlikely to pay off in the long run. Other means of reducing energy usage are now required.

Energy is lost through the building envelope via 3 main routes:

- Building fabric losses, through the insulation.
- Linear thermal bridging, through building details and areas of reduced thermal resistance.
- Air-tightness, the entry of cold air through joints and interfaces, which requires heating to the building's ambient temperature.

Fig. 1. Factors which affect building CO₂ emission rate.

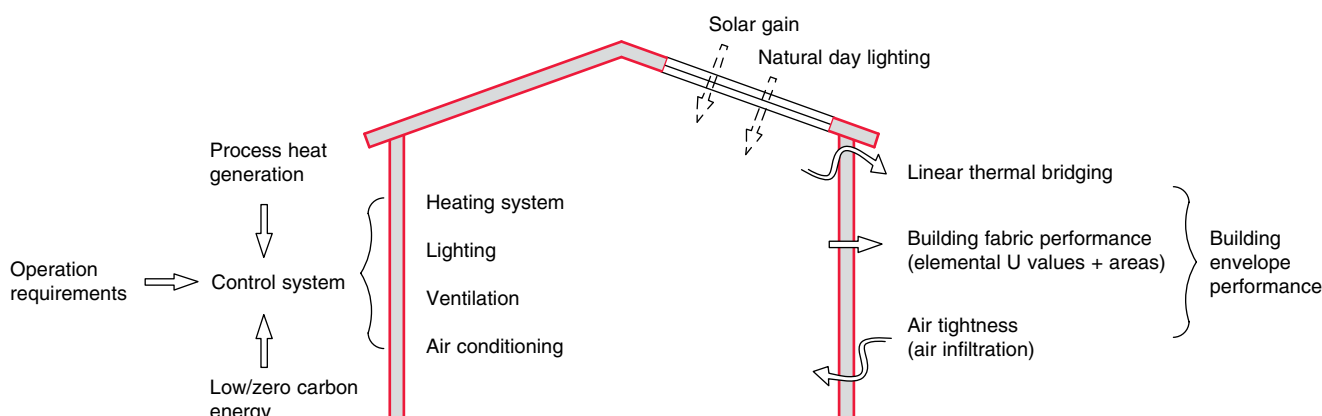

The evaluation of air infiltration rates for large buildings has established the following relationship:

$$\text{Air changes/hour} = \frac{\text{Air-tightness @ 50 Pa} \times \text{envelope area}^*}{\text{Cladding area} \times 60}$$

* Envelope area is the cladding and floor slab area combined.

The energy (watts) required to heat the cold air entering the building is given by:

$$\frac{\text{Air changes/hour} \times \text{building volume} \times \text{specific heat capacity of air} \times \text{density of air} \times \text{temp raise}}{3600}$$

Fig. 2. Building envelope energy losses.

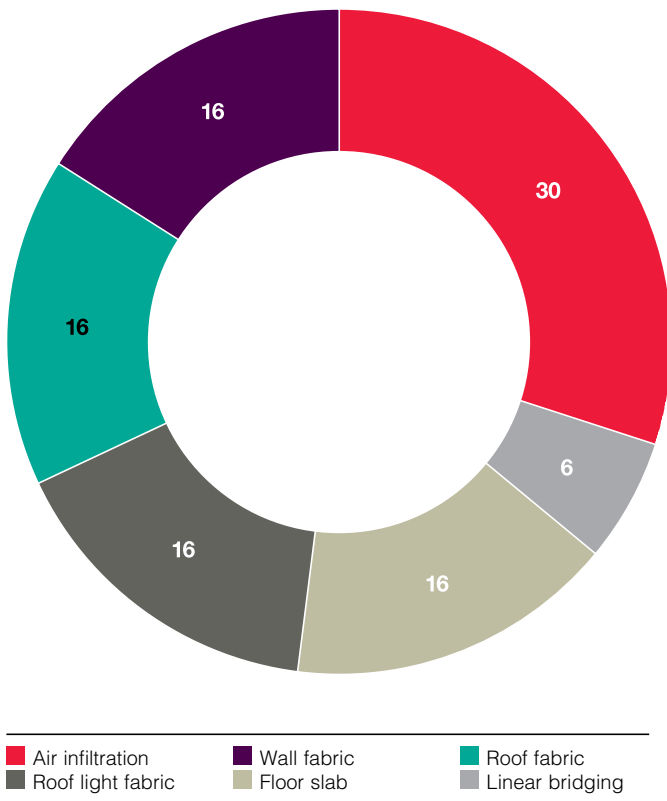

Note: values dependant on building geometry.

As illustrated, air-tightness offers the greatest opportunity for reducing heat loss through the building envelope. To maintain a good working environment within a building, a number of air changes per hour are necessary, dependent on activity levels. Best practice dictates that the building envelope should be as air-tight as possible, with controlled ventilation.

Building regulation requirements. Approved document L (2006)

Air-tightness is measured in m³ of air per hour per m² of building envelope at an applied pressure of 50 Pa. The area of the building envelope includes the walls, roof and floor slab. In practice, the floor slab can be considered air-tight.

The concept of air-tightness was first introduced into Building Regulations in England and Wales in the 2002 revision of “approved document L”. In this document,

a maximum allowable air leakage rate of 10 m³/h/m² was introduced for all buildings other than dwellings greater than 1000 m².

The 2006 update to Part L has extended this further. All buildings must be pressure tested, unless the floor area is less than 500 m², when a default value of 15 m³/h/m² can be used. For buildings over 500 m², a maximum reasonable design limit for air-tightness is 10 m³/h/m².

The new requirements are less prescriptive than 2002, however it will be difficult to meet the overall building CO₂ emission rate without a reasonably air-tight building envelope.

Air-tightness is tested using a number of large mobile fan units, to pressurise the building to 50 Pa. The volume of air leakage is divided by the cladding (including floor slab) area.

Potential air leakage paths

Pre-finished steel cladding is inherently air-tight. The management of the interfaces between the cladding sheets is critical to ensure a high performance building envelope. The following interfaces should be considered:

- Metal cladding side and end lap joints.
- The interface between metal cladding and pre-fabricated flashings at building corners, ridges, eaves and verges.

- The interface between metal cladding and the floor slab/dwarf wall and other building envelope materials.
- Unplanned penetrations in the cladding.

This paper assesses the requirements for metal cladding side and end lap joints and the interface between metal cladding and flashing, although some of these principles can also be applied to other interfaces and penetrations.

Achieving air-tightness

In a typical pre-finished steel-clad building, the air-tightness barrier is provided by the interior (or “liner”) side of the envelope.

While the outer sheet of an insulated envelope will provide weather protection, and will be sealed in order to prevent water leaks, it is important that it is not relied upon for air-tightness. This is for two main reasons:

1. The insulation cavity on a build up system is slightly ventilated to allow air movement and so eliminate condensation build up in the cavity.

2. Sealing at the liner side will prevent water vapour from inside the building penetrating the insulation.

The first step in constructing an air-tight building is to identify the liner as the air-tightness barrier and ensure this is focused on during the design and construction of the building envelope.

The means of achieving air-tightness for a building using a built-up, insulated, pre-finished steel cladding system will be different from one clad with factory insulated composite panels. Both systems can provide extremely good air-tightness, using good detailing and construction.

Built-up system

Air-tightness for built-up systems is generated by the liner sheet. Sealant tapes or beads are used to seal the overlap joints between adjacent sheets. It is normal practice to have a slightly vented insulation cavity to reduce condensation risks. The external or weather sheet of the building envelope does not normally contribute to air-tightness.

Fig. 3. Cross section schematic through a built-up system.

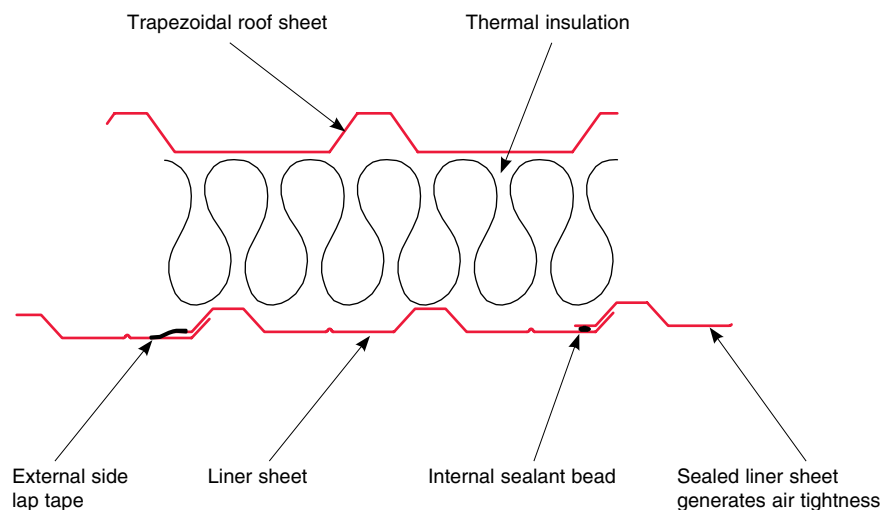

Factory insulated composite panels

Air-tightness is achieved by the compression of factory fitted seals on the liner side of the joint. Sealant fitted on the outer sheet is for weather tightness only. Care must be taken to ensure that condensation does not occur inside the joint.

The position of the factory filled seals will be specific to the individual panel. For further information on seal position and potential condensation contact the cladding system manufacturer.

Fig. 4. Cross section schematic through a factory insulated composite panel

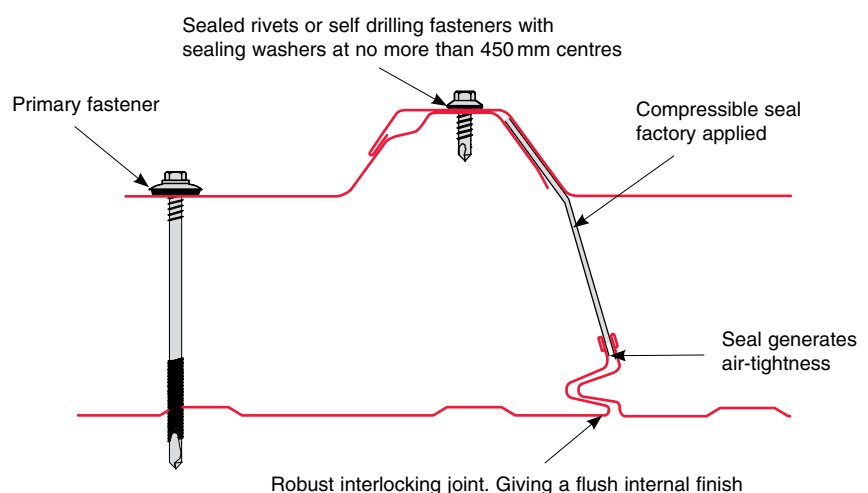

Air-tightness testing facilities

Corus has established the Colorcoat® Centre for the Building Envelope at Oxford Brookes University, to support research in the use of pre-finished steel in the building envelope. A key area of study is how the building envelope can contribute to the aims of sustainable development, with work focusing on minimising operational energy as well as life cycle analysis and the development of modern methods of construction.

This technology will be invaluable in helping architects and contractors comply with the changes to Part L (2006) Building Regulations. In developing these testing facilities with Oxford Brookes University Architectural School, Corus believes the results will be used to provide more air-tight building details, reducing energy bills for the client and providing more security from uncertain fuel prices.

At the Colorcoat® Centre different cladding joint assemblies have been fabricated on a test rig, which was

then pressurised to 50 Pa (the same pressure used to test whole buildings). The pressure inside the test rig is automatically controlled, allowing the air leakage rate for the cladding system and per linear metre of joint to be calculated. The results of this study show that good air-tightness is achieved by what would be recognised as “best practice” rather than costly new systems.

A number of cladding joints have been assessed in order to provide this guidance:

Built-up systems

- Side lap joints.
- End lap joints.
- Side lap to flashing joints.
- End lap to flashing joints.

Factory insulated composite panel systems

- Side lap joints.
- End lap joints.
- Side lap to flashing joints.
- End lap to flashing joints.

Fig. 5. Schematic of air-tightness test cell.

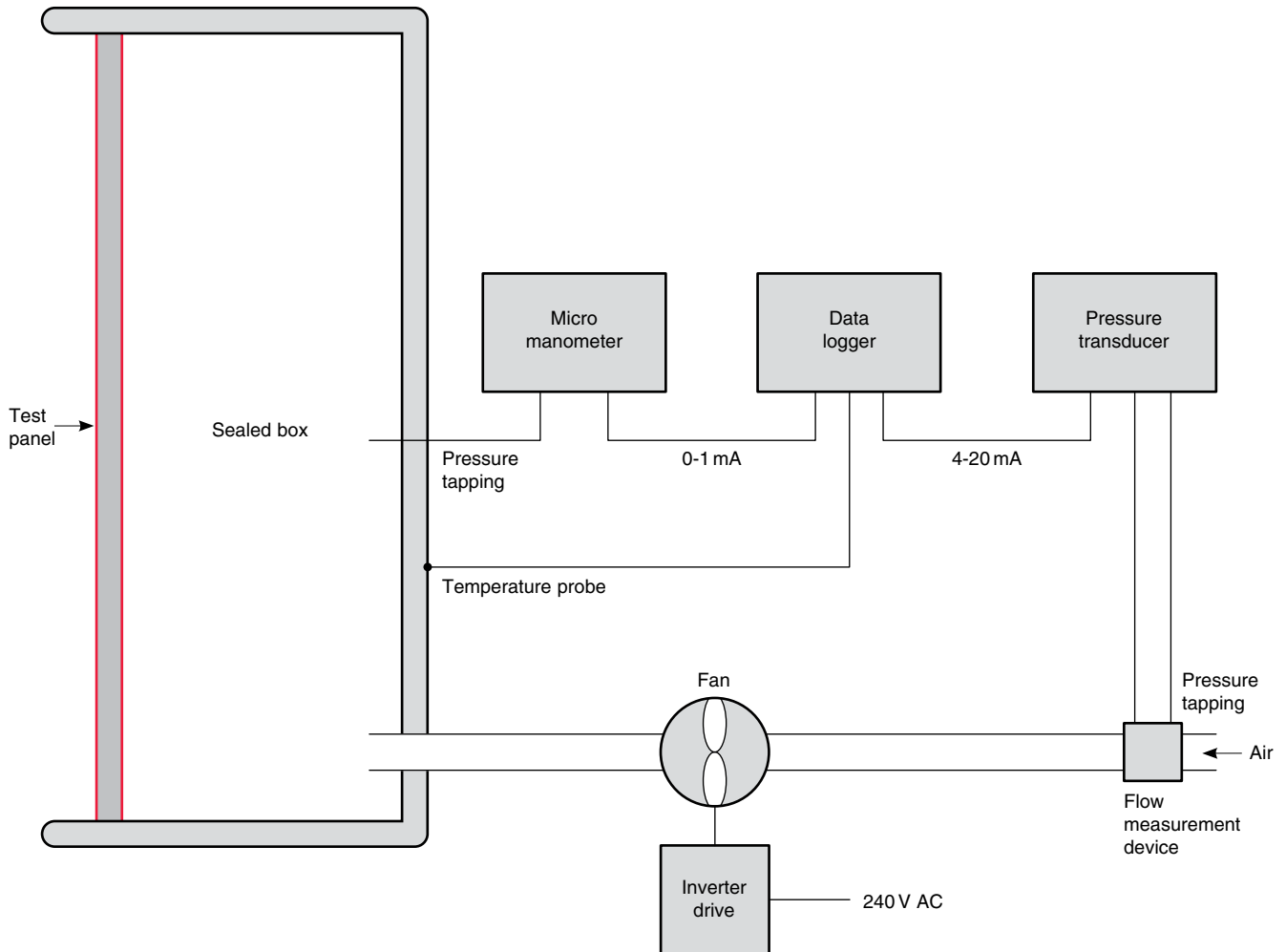

Achieving air-tightness using built-up systems

Built-up system side lap joints

Fig. 6. Cross section schematic through a built-up system.

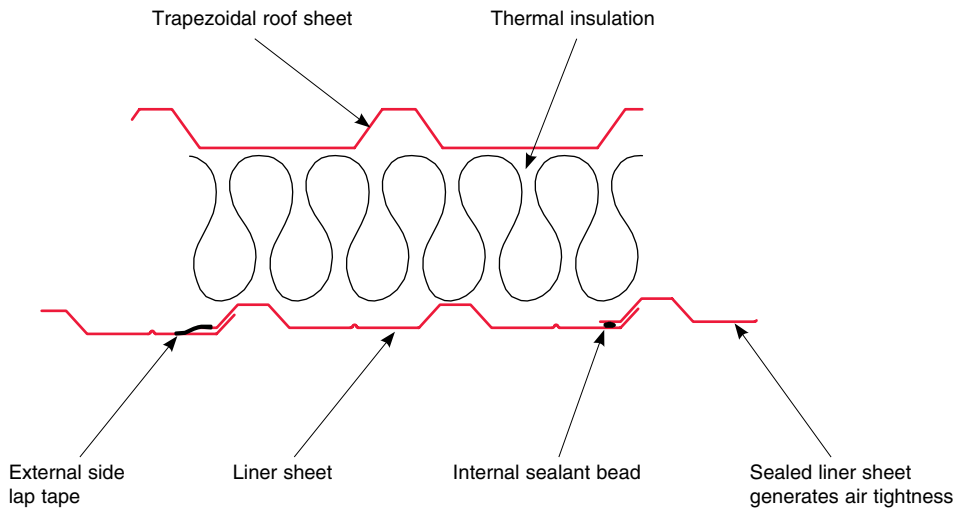

Side lap joints are formed where the profiled edge of one sheet overlaps the edge of the adjacent sheet. Liner sheets are normally 0.4 mm or 0.7 mm thick. The joint is sealed either using a sealant bead, which is placed inside the overlap joint, or an external tape, which is placed over the joint line on the cavity side of the liner sheet. The joint can be reinforced with stitcher screws or rivets. This is a requirement for most firewall constructions.

Side lap joints account for approximately 75% of joint length in the cladding. There is approximately 1 metre of joint for every square metre of cladding; depending on the sheet cover width. For this reason, effective sealing of this joint provides the basis of an air-tight cladding system.

Any edge damage to the sheet profile will affect the tightness of the overlap joint and the performance of unsealed joints will be poor and have a high

degree of variability. The use of a good quality sealant tape (such as Polyband or T-foil) or an internal sealant bead will produce a good quality air-tight joint.

When using an external tape, it is important to note that the stitcher screws will not provide any additional air-tightness, although they can add

to the longevity of the joint. When using an internal sealant bead, stitcher screws are necessary for compression of the bead, increasing the performance and longevity of the joint.

(Consult cladding system manufacturers for the recommended size and grade of sealant beads).

Table 1: Side lap joint configurations and corresponding air leakage rates

Joint details	Leakage rate m ³ /h/m	
	0.4 mm liner	0.7 mm liner
Unsealed unstitched	>10.00	>10.00
Unsealed stitched @ 450 mm	>5.00	>5.00
External sealant tape	<0.20	<0.20
External sealant tape and stitching @ 450 mm	<0.20	<0.20
Internal sealant bead	<0.25	<0.40
Internal sealant bead and stitching @ 450 mm	<0.20	<0.20

Key

■ Recommended specification

Built-up system end lap joints

Fig. 7. Schematic of a built-up system end lap joint.

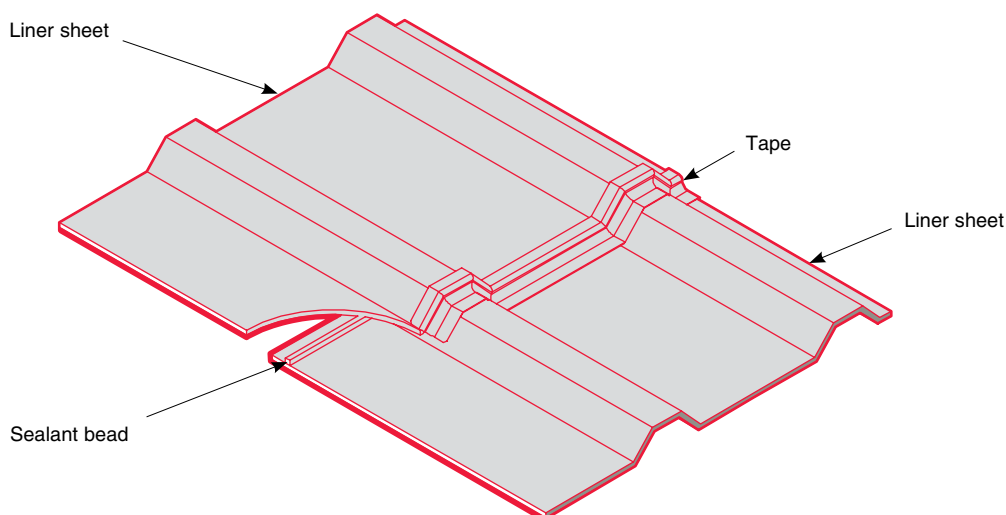

End lap joints are formed where the profiled end of one sheet overlaps the end of the adjacent sheet. The minimum recommended overlap is 60 mm. Liner sheets are normally 0.4 mm or 0.7 mm thick. The joint is sealed using a sealant bead, which is placed inside the overlap joint, or using an external tape, which is placed over the joint line on the cavity side of the liner sheet. The joint is reinforced with stitcher screws or rivets.

Stitcher screws should be fitted in every valley to provide compression of the sealant bead. The use of a good quality sealant bead will produce a good quality air-tight joint. If the sheet is secured only in alternate valleys, the unsecured valleys can open slightly, stressing the sealant bead and compromising the performance and longevity of the joint.

An external sealant tape can provide an air-tight joint, but is difficult to secure accurately around the profiles, which

can lead to workmanship issues and reduced performance. Poorly laid tape can also trap internal condensation, resulting in potential corrosion of the liner sheet.

(Consult cladding system manufacturer for the recommended size and grade of sealant beads/tapes).

Table 2: End lap joint configurations and corresponding air leakage rates

Joint details	Leakage rate m ³ /h/m	
	0.4 mm liner	0.7 mm liner
Unsealed, stitched alternate valleys	<45.00	<45.00
Unsealed, stitched every valley	<15.00	<15.00
Internal sealant bead, stitched alternate valleys	<1.00	<0.50
Internal sealant bead stitched every valley	<0.30	<0.30
External sealant tape, stitched alternate valleys	<0.20	<0.20
External sealant tape, stitched every valley	<0.20	<0.20

Key

■ Recommended specification

Built-up system side lap to flashing joints

Fig. 8. Cross section schematic of a built-up system side lap to flashing joint.

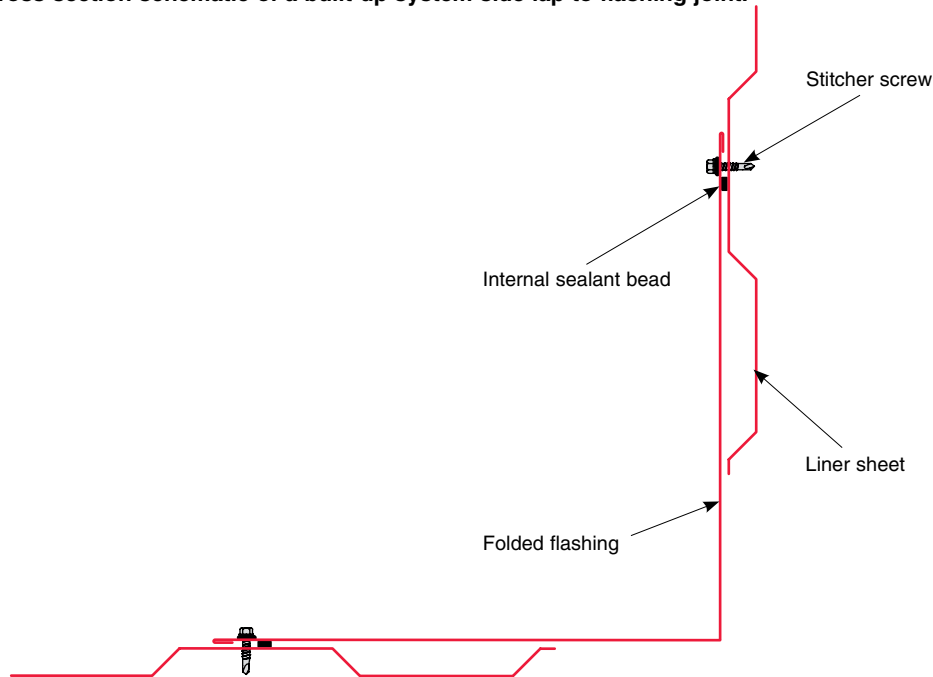

This joint is formed where the edge of the folded flashing sheet overlaps the edge of the adjacent sheet as in a vertical corner. Liner sheets are normally 0.4 mm or 0.7 mm thick, flashings are normally 0.7 mm thick. The overlap joint is sealed using a sealant bead, which is placed inside the overlap. The joint is reinforced with stitcher screws or rivets.

The performance of this joint is very similar to a normal side lap joint. The use of stitcher screws is essential to ensure adequate compression of the internal sealant bead. An external sealant tape can also be used with some liner sheet profiles. This should be placed on the cavity side.

(Consult cladding system manufacturers for the recommended size and grade of sealant beads).

Table 3: Side lap/flashing joint configurations and corresponding air leakage rates

Joint details	Leakage rate m ³ /h/m	
	0.4 mm liner	0.7 mm liner
Internal sealant bead, stitched @ 900 mm	<0.25	<0.25
Internal sealant bead, stitched @ 450 mm	<0.20	<0.20

Key

■ Recommended specification

Built-up system end lap to flashing joints

Fig. 9. Schematic of a built-up system end lap to flashing joint.

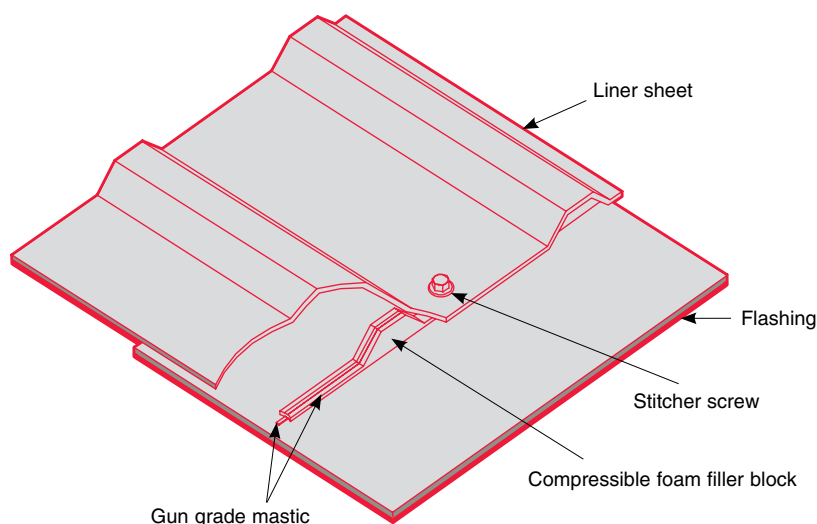

This joint is formed where the end of the profiled sheet overlaps the folded flashing sheet as in a ridge or eaves detail. The minimum recommended overlap is 75 mm. Liner sheets are normally 0.4 mm or 0.7 mm thick, whilst flashings are normally 0.7 mm thick. The joint is sealed using profiled filler blocks, which fit into the liner sheet profile and become compressed between the profile and the flashing. Filler blocks are generally made from Ethylene Propylene Diene Monomer (EPDM) or Polyethylene (PE) foam. Stitcher screws create compression and reinforcement of the joint.

It is essential that filler blocks are matched to the profile of the cladding sheet used. The use of a suitable gun-grade mastic to bond the filler blocks in position will generally increase performance and also assists with locating the blocks during assembly. To ensure good compression of the

filler blocks and longevity of the joint, the sheeting should be secured through every valley.

There is no discernable difference in performance between EPDM and PE filler blocks.

Table 4: End lap/flashing joint configurations and corresponding air leakage rates

Joint details	Leakage rate m ³ /h/m	
	0.4 mm liner	0.7 mm liner
EPDM filler block stitched alternate valleys	>10.00	<5.00
PE filler block stitched alternate valleys	>10.00	<5.00
Bonded EPDM filler block stitched alternate valleys	<2.00	<2.00
Bonded PE filler block stitched alternate valleys	<2.00	<2.00
EPDM filler block stitched every valleys	<0.50	<0.50
PE filler block stitched every valleys	<0.50	<0.50
Bonded EPDM filler block stitched every valleys	<0.25	<0.25
Bonded PE filler block stitched every valley	<0.25	<0.25

Key

■ Recommended specification

Achieving air-tightness using factory insulated composite panel systems

Factory insulated composite panel system side lap joints

Fig. 10. Cross section schematic through a factory insulated composite panel system.

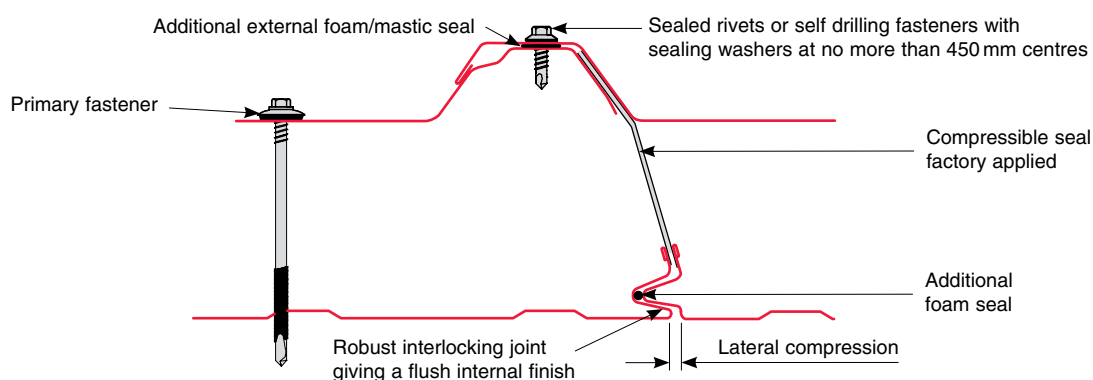

The edge detail of a factory insulated composite panel is designed to interlock with its adjacent panel, forming an air-tight and weather-tight seal. A compressible foam seal is usually incorporated into the edge tape detail, which seals against the adjacent panel. The two panels must be held tightly together during installation to ensure adequate compression of the seal. Additional supplementary sealing may also be used.

Side lap joints typically account for approximately 75% of joint length in the cladding. There is approximately 1 metre of joint for every square metre

of cladding, depending on the panel cover width. For this reason, effective sealing of these joints provide the basis of an air-tight cladding system.

Performance of the basic joint is reliant on adequate compression of the internal tape seal. Any edge damage to the panel or panel misalignment, could mean that joints do not fully close, therefore compromising air-tightness. The use of an external sealant bead, or foam seal, in addition to the internal edge tape seal will greatly enhance performance and tolerance of the joint to inadequate lateral compression.

It should be noted that this in effect moves the air-tight barrier to the outer sheet and could potentially cause a build up of condensation in the joint detail.

The use of a supplementary foam seal (or mastic bead) in the interlocking joint on the liner side of the panel will greatly enhance performance and tolerance of the joint to inadequate lateral compression. Importantly, this also maintains the air seal on the liner side of the panel.

(Consult cladding system manufacturers for recommended size and grade of sealant/foam seals.)

Table 5: Side lap joint configurations and corresponding air leakage rates for varying lateral compression

Joint details	Leakage rate m ³ /h/m			
	Foam edge seal only	Foam edge and external sealant bead	Foam edge seal and external foam seal	Foam edge seal additional internal foam seal
Fully compressed joint	<0.50	<0.20	<0.20	<0.20
Joint compressed to 1.75 mm	<5.00	<0.20	<0.20	<0.20
Joint compressed to 3.5 mm	>10.00	<0.20	<0.20	<1.50*

* The performance of the joint is dependant on the size of the internal foam seal fitted. A larger diameter seal will be more tolerant of inadequate joint compression.

Factory insulated composite panel system end lap joints

Fig. 11. Cross section schematic of a factory insulated composite panel system end lap joint.

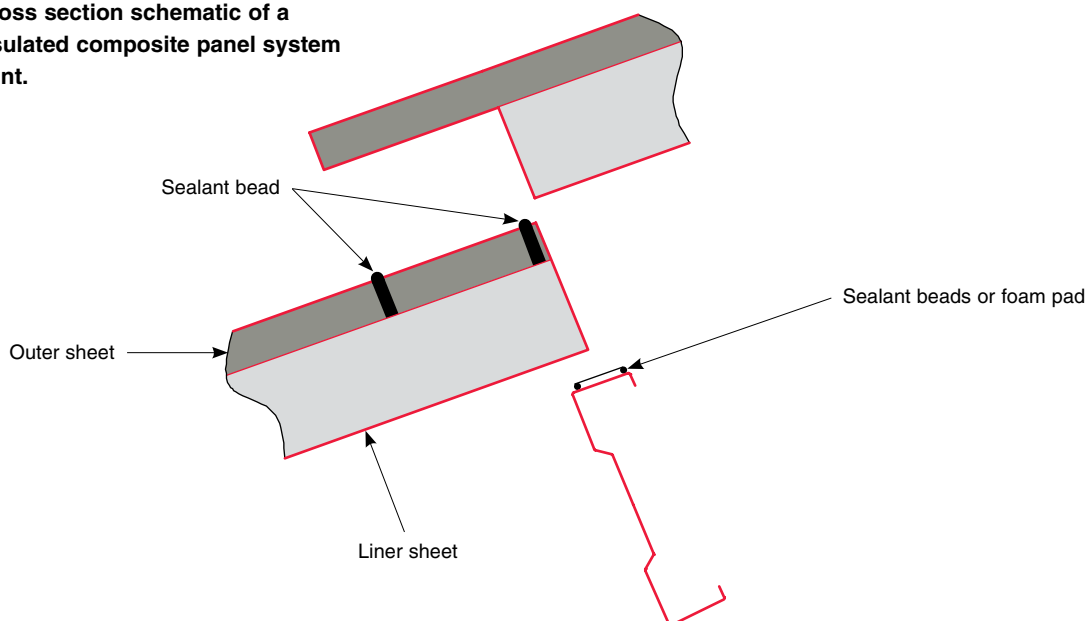

This joint is formed where the profiled end of an external sheet overlaps the end of the adjacent sheet. The joint must be sited over a purlin/sheeting rail. The liner and insulation foam on the overlapping panel must be cut back to facilitate this, a process which is usually done during panel manufacture. The minimum recommended overlap is 100 mm. The joint is sealed using a sealant bead, which is placed inside the overlap joint. A compressible foam

tape or mastic bead, should also be applied to the purlin. The joint is reinforced with stitcher screws or rivets, which also compress the sealant beads.

The use of sealant beads in the external sheet overlap joint will, when adequately secured, result in an air-tight joint. Alternate through fixings will provide adequate compression of the sealant beads. It should be noted, however, that this is effectively moving the

air-tight barrier to the outer sheet, which could potentially cause a build up of condensation in the joint detail. The use of supplementary foam seals (or mastic beads) on the purlin will provide an effective seal on the liner side of the panel and will greatly enhance performance.

(Consult cladding system manufacturers for recommended size and grade of sealant/foam seals.)

Table 6: End lap joint configurations and corresponding air leakage rates

Joint details	Leakage rate m ³ /h/m
No sealant, alternate valley through fix only	>2.50
No sealant, alternate valley through fix. Alternate valley stitched	>2.50
2 sealant beads, alternate valley through fix only	<0.30
2 sealant beads, alternate valley through fix. Alternate valley stitched	<0.30
2 sealant beads, alternate valley through fix Foam pad/sealant beads on purlin	<0.20

Key

■ Recommended specification

Factory insulated composite panel system side lap to flashing joints

Fig. 12. Cross section schematic of a factory insulated composite panel system side lap to flashing joint.

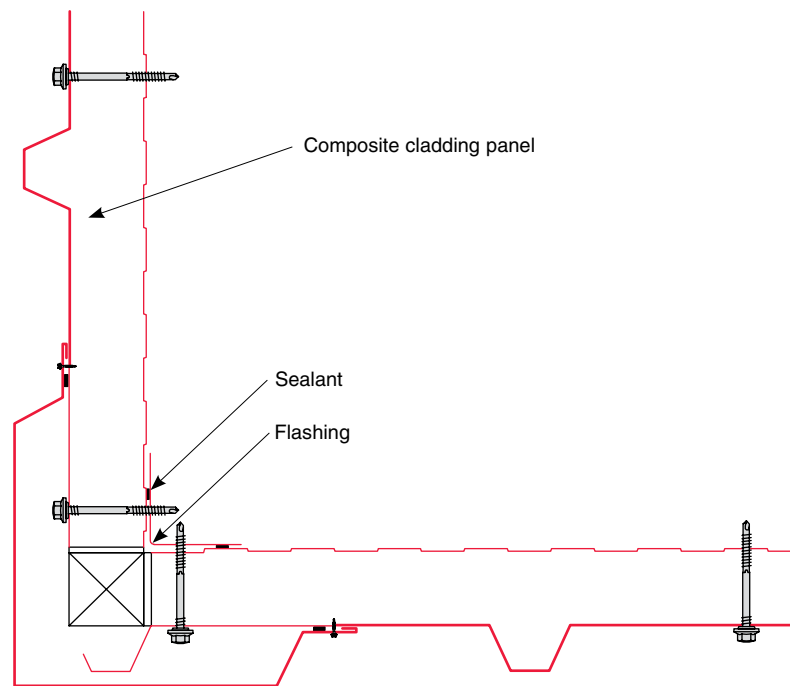

This joint is formed where the panel edge overlaps the edge of the folded flashing sheet as in a vertical corner. Flashings are normally 0.7 mm thick. The overlap joint is sealed using a sealant bead, which is placed inside the overlap joint. The joint is reinforced with stitcher screws or rivets, which also compress the sealant bead.

The performance of this joint is very similar to a built-up system, flashing joint. The use of stitcher screws is essential to ensure adequate compression of the internal sealant bead.

(Consult cladding system manufacturers for recommended size and grade of sealant/foam seals.)

Table 7: Side lap / flashing joint configurations and corresponding air leakage rates

Joint details	Leakage rate m ³ /h/m
Internal sealant bead, stitched @ 1900 mm	<1.50
Internal sealant bead, stitched @ 900 mm	<0.25
Internal sealant bead, stitched @ 450 mm	<0.20

Key

■ Recommended specification

Factory insulated composite panel system end lap to flashing joints

Fig. 13. Schematic of a factory insulated composite panel system end lap to flashing joint.

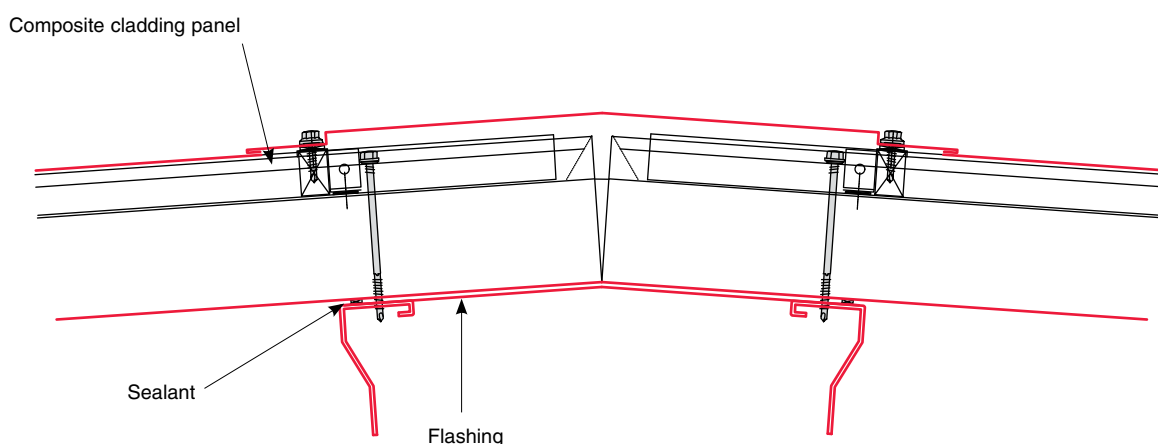

This joint is formed where the end of the panel overlaps the edge of the folded flashing sheet as in a ridge or eaves detail. Flashings are normally 0.7mm thick. The overlap joint is sealed using a sealant bead which is placed inside the overlap joint. The minimum recommended overlap is 75mm.

It should be noted that profiled filler blocks are not normally used,

due to the very shallow micro rib/plank profile of the internal liner sheet. Compression of the sealant and reinforcement of the joint is created by stitcher screws/primary fasteners.

Due to the rigidity of the panel, there is minimal difference in performance when additional fasteners are used. Through fixings should be specified

for every valley for structural (wind load) requirements.

The sealant bead must be of an adequate size to accommodate the small profile in the liner sheet of the composite panel.

(Consult cladding system manufacturers for recommended size and grade of sealant/foam seals.)

Table 8: End lap/flashing joint configurations and corresponding air leakage rates

Joint details	Leakage rate m ³ /h/m
No sealant. Alternate through fix	>20.00
Internal sealant bead. Alternate through fix	<0.20
Internal sealant bead through fix every valley	<0.20

Key

■ Recommended specification

Applying the results in building design and construction

The tables below summarise recommended practices and measured joint leakage rates. The building envelope is configured using combinations of the joints included here, for example, a gable joint incorporates flashing to side lap and flashing to end lap joints.

Table 9: Built-up system – recommended joint sealing practice

Joint details	Recommendation	Leakage rate m ³ /h/m
Side lap joint	External sealant tape	<0.20
	Internal sealant bead, stitched @ 450 mm	<0.20
Side lap flashing joint	Internal sealant bead, stitched @ 450 mm	<0.20
	External sealant tape	<0.20
End lap joint	Internal sealant bead, stitched every valley	<0.30
End lap flashing joint	Bonded EPDM or PE filler block, stitched every valley	<0.25

Table 10: Factory insulated composite panels – recommended joint sealing practice

Joint details	Recommendation	Leakage rate m ³ /h/m
Side lap joint	Fully compressed edge seal	<0.50
	Additional internal foam seal on liner sheet interlock	<0.20
Side lap flashing joint	Internal sealant bead, stitched @ 450 mm	<0.20
End lap joint	2 sealant beads, alternate valley through fix. Foam pad/sealant beads on purlin	<0.10
End lap flashing joint	Internal sealant bead, through fix every valley	<0.20

A pre-finished steel building envelope can easily surpass the requirements of the revised Part L (2006) provided that the metal cladding joints are correctly installed in accordance with the system manufacturers guidance and that an approved sealant tape or internal sealant bead is used. Consult with cladding system manufacturers for the recommended size and grade of sealant bead

It is important to recognise that construction site conditions are not always ideal. The Corus Colorcoat®

Centre for the Building Envelope carried out tests to assess whether real world issues, such as damp or dirty pre-finished steel surfaces, will affect the bond of the sealant tape to the liner sheet. These indicate that provided the material is only moderately wet /dirty, (typical of early morning dew and airborne construction dust) and that adequate pressure is applied when fitting the sealant tape, a good quality seal can still be achieved. Care must be taken to ensure that damage does not occur to sheet edges and that debris is not present in overlap joints.

Table 11: Built-up systems. Side lap joint leakage rates under simulated site conditions

Joint details	Leakage rate m ³ /h/m			
	Standard joint	Damp	Dirty	Reduced pressure*
Unsealed unstitched	>10.00	>10.00	>10.00	NA
Unsealed stitched @ 450 mm	>5.00	>5.00	>5.00	NA
External sealant tape	<0.20	<0.20	<0.50	<0.50

* Reduced pressure was simulated by applying the tape using a hand brush.

Provided pre-finished steel cladding is correctly installed, the main sources of air infiltration will be other elements of the building envelope, such as: interfaces with other cladding materials, for example masonry dwarf walls or the floor slab, unplanned penetrations through the building envelope and gaps around vehicle access doors. Further work is currently underway at the Corus Colorcoat® Centre for the building envelope and better understanding of

these complex joints. Use of the principles detailed in the Colorcoat® Technical Paper will minimise air leakage around such elements but it is important at the design stage to consider minimising difficult functions or leaky materials such as blockwork or masonry.

Attention to detail and a high standard of site workmanship are required to ensure that unplanned leakage paths are minimised.

Testing has been carried out to establish the leakage rate through unplanned holes in the metal cladding.

Building practice has focused on sealing the outer sheet of a built-up system to ensure a weather tight envelope. Similar attention to detail should also be paid to the seal on the liner side of the envelope to ensure continuity of the air-tight layer.

Fig. 14. Air-leakage rate for holes.

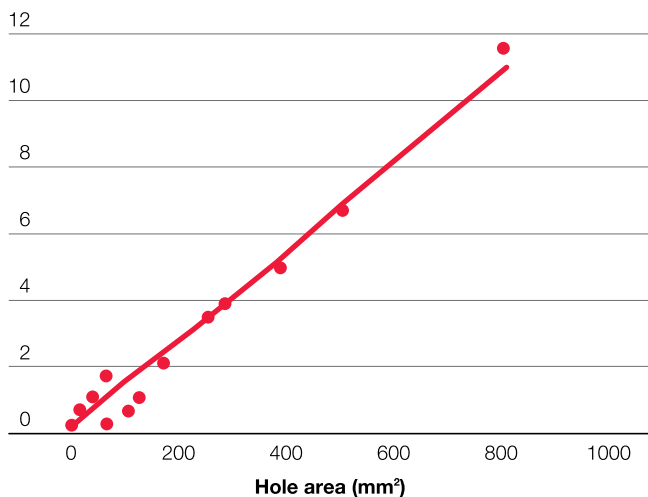

Key

■ Air leakage rate (m³/h)

Air-tightness in context

This illustrates how a building would achieve an air-tightness rating which complies with Part L Regulations. For the dimensions specified below this building would be allowed a maximum air permeability at 50 Pa of $10 \times 3729 = 37290 \text{ m}^3/\text{h}$ to pass Part L.

Table 12: Details of joint lengths and associated average joint leakage rates

Building dimensions			
Height (m)	8	Number of ridges	1
Width (m)	20	Roof pitch height (m)	1.1
Length (m)	60	Roof slope length (m)	10.1
Wall panel width (m)	1	Floor area (m ²)	1200.0
Wall panel height (m)	4	Roof area (m ²)	1206.6
Roof panel width (m)	1	Wall area (m ²)	1322.0
Roof panel height (m)	3.3	Envelope area including floor (m ²)	3728.7
Roof pitch (degrees)	6	Total enclosed volume (m ³)	9610.5

Joint details	Leakage from joints – linear leakage of (m³/h/m)						
		Length (m)	0.10	0.25	0.50	1.00	2.00
Corner	32.0	3.20	8.00	16.00	32.00	64.00	96.00
Wall side lap	1266.9	126.69	316.73	633.46	1266.92	2533.84	3800.76
Wall end lap	160.0	16.00	40.00	80.00	160.00	320.00	480.00
Roof side lap	1186.5	118.65	296.62	593.25	1186.50	2373.00	3559.50
Roof end lap	240.0	24.00	60.00	120.00	240.00	480.00	720.00
Verge	40.2	4.02	10.06	20.11	40.22	80.44	120.66
Eaves	120.0	12.00	30.00	60.00	120.00	240.00	360.00
Perimeter	160.0	16.00	40.00	80.00	160.00	320.00	480.00
Ridge	60.0	6.00	15.00	30.00	60.00	120.00	180.00
Valley	0.0	0.00	0.00	0.00	0.00	0.00	0.00
Total leakage		327	816	1633	3266	6531	9797

If all the relevant joints had a linear leakage of $0.5 \text{ m}^3/\text{h}/\text{m}$, the total leakage from the pre-finished steel envelope attributable to joints would be $0.43 \text{ m}^3/\text{h}/\text{m}^2$ or 4.3% of the maximum allowable leakage.

It can be seen from this example that correct sealing of the metal to metal end and side lap joints, which form the majority of the potential air leakage paths, forms the basics of a good air tightness performance.

Conclusions

In summary, it is worth remembering that steel is an inherently air-tight material, so the only air-leakage paths in a steel building envelope are where there are gaps left at junctions. Adopting the approaches detailed in this paper should minimise gaps at the majority of junctions. It should be noted, however, that a target air-leakage rate of 10, 5 or even 3 m³/m²/h allows, on average, a gap of 700 mm², 380 mm² or 200 mm² for every 1 m². Given that the target air-tightness is for the whole building (including all openings, interfaces, floors, roof and walls) it is essential that the techniques described here

are adopted for the areas which are relatively easy to control, since gaps will inevitably appear elsewhere in the construction.

Experience has shown that with close attention to detail, steel-clad buildings should have no difficulty in achieving air-leakage rates of no more than 5 m³/m²/h, and often even less than 3 m³/m²/h. However, air-leakage is highly dependent on building geometry. Simple, large buildings have proportionately less potentially-leaky interfaces than more complex, small ones.

CPD accreditation

This paper has been assessed and approved as conforming to RIBA CPD guidelines. As such the content has been designated to fit under the following core curriculum headings:

General Headings

- 1 Professional context
- 2 Construction Skills

Subjects

- 1 Sustainable architecture
- 2 Specification writing and choosing materials

Knowledge level

General awareness

To receive a CPD certificate for this paper, please go to www.colorcoat-online.com/cpd where you will be asked to correctly answer five short questions on the content of the paper before being issued with an electronic certificate.



The Colorcoat® brand

The Colorcoat® brand provides the recognised mark of quality and metal envelope expertise from Corus. Developed over 40 years, Colorcoat® includes a range of pre-finished steel products with a proven track record on countless buildings worldwide, supported by a range of services, including guarantees, colour consultancy and expert advice and guidance.

Colorcoat® products and services

Colorcoat HPS200®

Eco-designed exclusive coating technology, superior performance and the comprehensive Confidex® Guarantee make Colorcoat HPS200® the most specified pre-finished steel product in Europe for roof and wall cladding. Now maintenance free for up to 30 years.

Colorcoat Prisma®

The ideal choice to deliver eye-catching buildings that will stand the test of time. Technically and aesthetically superior to PVDF (PVF2), Colorcoat Prisma® is readily available in the most popular solid and metallic colours. All backed up by the comprehensive Confidex® Guarantee providing cover for up to 25 years on walls.

Repertoire® Colour Consultancy

The Repertoire® Colour Consultancy can provide technical advice and guidance on standard as well as bespoke colours to feed the imagination and inspire design. Corus can match almost any shade from physical swatches to commonly used references such as RAL, NCS and British Standard and more unusual standards.

Colorcoat Connection® helpline

A dedicated helpline offering advice and guidance on the performance of Colorcoat® products, how to comply with Building Regulations, where to source complementary products and much, much more.

Confidex® Guarantee

Offers the most comprehensive guarantee for pre-finished steel products in Europe and provides peace of mind for up to 30 years. Unlike other guarantees, Confidex® covers cut edges for the entirety of the guarantee period and does not require mandatory annual inspections.

Confidex Sustain™

Provides a combined guarantee which covers the durability of the Colorcoat® pre-finished steel product and makes the pre-finished steel building envelope CarbonNeutral - the first in the world. Unavoidable CO₂ emissions from the pre-finished steel cladding system including fixings and insulation, are measured from cradle to grave and the impact offset. More than just offsetting, the aim is to encourage specification of the most sustainable pre-finished steel products and cladding systems.

Colorcoat® Building manual

Developed in consultation with architects and other construction professionals, the Colorcoat® Building manual incorporates over 40 years of Colorcoat® expertise. Recently been updated to cover the changes to Part L (2006) Building Regulations, it provides an invaluable guide to designing, specifying and constructing the metal building envelope.

If you require any further information please call the Colorcoat Connection® helpline. Alternatively, further information can be found in our Colorcoat® Building manual or at www.colorcoat-online.com





**There's only
one true
Colorcoat®**

Ensure that it's Colorcoat® by Corus

www.colorcoat-online.com

Trademarks of Corus

Colorcoat, Colorcoat Connection, Confidex, Confidex Sustain, HPS200, Prisma and Repertoire are trademarks of Corus.

Care has been taken to ensure that the contents of this publication are accurate, but Corus Group plc and its subsidiary companies do not accept responsibility for errors or for information that is found to be misleading. Suggestions for, or descriptions of, the end use or application of products or methods of working are for information only and Corus Group plc and its subsidiaries accept no liability in respect thereof.

Before using products or services supplied or manufactured by Corus Group plc and its subsidiaries, customers should satisfy themselves as to their suitability.

Copyright 2007 Corus

Language English 0807

Sales contact details

Corus Colors
Shotton Works
Deeside
Flintshire CH5 2NH
United Kingdom

T: +44 (0)1244 812345

F: +44 (0)1244 831132

www.colorcoat-online.com

Colorcoat Connection® helpline

T: +44 (0)1244 892434

F: +44 (0)1244 836134

e-mail: colorcoat.connection@corusgroup.com